

SPECIFICATIONS HFP-50 / 12

PRESS	POWER	BORE	STROKE	RAM SPEED		CAPACITY (TONS)	WEIGHT (LBS.)	SHIPPING DIMENSIONS		
				PRESS	RETURN			L	W	H
HFP-50	5 HP 230 1 phase	6"	12"	20 IPM	24 IPM	50	1,600	50"	86"	93"
BP-12	Same	3"	20"	80 IPM	144 IPM	12	Same	Same		

Standard voltages available - please specify when ordering.

H FRAME PRESS / BROACH PRESS 50 Ton / 12 Ton

STANDARD FEATURES

- ✓ **Electric / Hydraulic operation** provides smooth, consistent pressing action.
- ✓ **Open sides** to facilitate work on long pieces.
- ✓ **Flat ram nose** can be easily changed to allow the user to adapt the press to a specific job.
- ✓ **Quality Baldor motor**, low speed.
- ✓ **Low speed pump** - quiet, dependable operation.
- ✓ **Self-locking** table design eliminates lateral movement.
- ✓ **Double-acting** cylinder permits pulling as well as pressing ram action.
- ✓ **Hydraulic power-lift** for vertical displacement of table.
- ✓ **Cylinder activation** is fingertip controlled, the more the hand lever is engaged the more the ram movement is accelerated. This allows the operator to control the proper speed for the task.
- ✓ **High capacity** 10 GAL. hydraulic oil reservoir.
- ✓ **Low pressure** hydraulic system maintains lower oil temperatures, resulting in higher efficiency and safer operation.

STANDARD FEATURES 12 TON

- ✓ **Pressure regulator** to limit the ram pressure.
- ✓ **Speed control** limits the maximum speed of ram travel, allowing operator to select the proper speed for the task.

AVAILABLE OPTIONS 50 TON

- VB-50** V BLOCKS matched pair.
- PR-50** Pressure regulator to limit the ram pressure.
- FSG-50** Front safety guard for operator protection.
- FPS-50** Foot pedal-electric solenoid valve for hands-free operation, c/w electric control panel.
- ASC-50** Adjustable stroke control c/w foot pedal-electric solenoid valve and electric control panel.
- 6-18** 18 Inch stroke cylinder.
- 6-24** 24 Inch stroke cylinder.

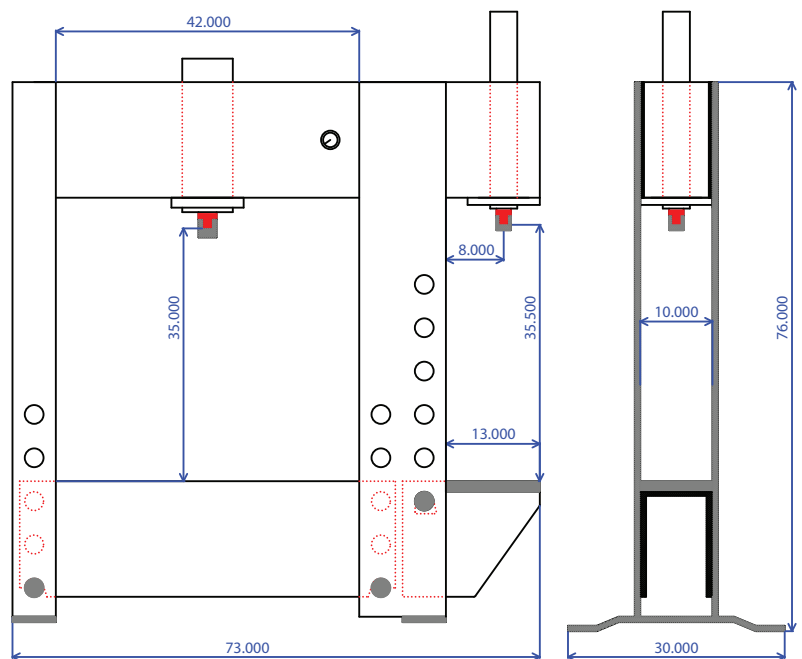

Custom designs available
We Build Them your Way!